

FMCSA's **Conspicuity** Requirements for Commercial Motor Vehicles



U.S. Department of Transportation
**Federal Motor Carrier
Safety Administration**



Introduction

The FMCSA has regulations requiring the use of conspicuity materials (i.e., retroreflective sheeting (or reflex reflectors)) on trailers and the rear of truck tractors. The rules are intended to reduce the incidence of motorists crashing into the sides or rear of trailers at nighttime and under other conditions of reduced visibility, and to reduce the incidence of motorists rear-ending truck tractors (being operated without trailers) under the same conditions.

There are three separate groups of commercial motor vehicles subject to the FMCSA's requirements and the date of manufacture for the vehicle must be known to determine the applicability of the rules to the vehicle. The rules cover trailers manufactured on or after December 1, 1993, the retrofitting of trailers built before that date, and truck tractors built on or after July 1, 1997.

Requirements for Trailers Manufactured on or After December 1, 1993 (49 CFR 393.11)

On December 10, 1992, the National Highway Traffic Safety Administration (NHTSA) published a final rule requiring that trailers manufactured on or after December 1, 1993, which have an overall width of 2,032 mm (80 inches) or more and a gross vehicle weight rating (GVWR) of more than 4,536 kg (10,000 pounds), except pole trailers and trailers designed exclusively for living or office use, be equipped on the sides and rear with a means for making them more visible on the road.

The NHTSA rule allows trailer manufacturers to install either red and white retroreflective sheeting or reflex reflectors. Manufacturers of retroreflective sheeting or reflectors are required to certify compliance of their product with Federal Motor Vehicle Safety Standard (FMVSS) No. 108 (49 CFR 571.108) whether the product is for use as original or replacement equipment.

The manufacturers certification will consist of one of the following markings depending on the type of conspicuity material:

- DOT-C** Rectangular reflex reflectors certified as meeting the standard.
- DOT-C2** 50 millimeter (mm) wide retroreflective sheeting material certified as meeting the standard.
- DOT-C3** 75 mm wide retroreflective sheeting certified as meeting the standard.
- DOT-C4** 100 mm wide retroreflective sheeting certified as meeting the standard.

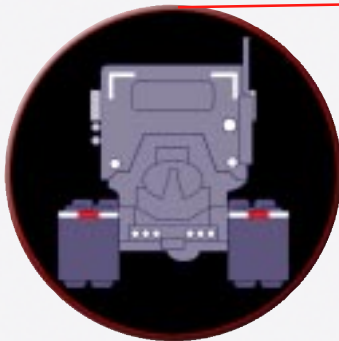

Currently, § 393.11 requires that all lamps and reflective devices on motor vehicles placed in operation after March 7, 1989, meet the requirements of FMVSS No. 108 in effect on the date of manufacture. Therefore, trailers manufactured on or after December 1, 1993, must have reflective devices of the type and in the locations specified by FMVSS No. 108, including the conspicuity treatments.

Locations for Conspicuity Treatment

The following is a description of where the conspicuity treatments have to be located on trailers. Illustrations of conspicuity treatments on some common types of trailers are also provided at the end of this publication.

Sides of the trailer

The retroreflective sheeting (or reflex reflectors) required by § 393.11 (through its cross reference to FMVSS No. 108) must be applied to each side of the trailer or semitrailer. Each strip of retroreflective sheeting (or reflex reflector) must be positioned as horizontally as practicable, beginning and ending as close to the front and rear as practicable. The conspicuity treatment is not required to be continuous. However, the sum of the length of all of the segments must be at least half of the length of the trailer and the spaces between the segments of the strip must be distributed as evenly as practicable. The centerline for each strip of retroreflective sheeting (or reflex reflector) must be between 375 mm (15 inches) and 1,525 mm (60 inches) above the road surface when measured with the trailer empty or unladen,

or as close as practicable to this area. If necessary to clear rivet heads or other similar obstructions, 50 mm (2 inches) wide retroreflective sheeting may be separated into two 25 mm (1 inch) wide strips of the same length and color, separated by a space of not more than 25 mm (1 inch).

Lower rear area of the trailer

The rear of each trailer and semitrailer must be equipped with retroreflective sheeting (or reflex reflectors). Each strip of retroreflective sheeting (or reflex reflector) must be positioned as horizontally as practicable, extending across the full width of the trailer, beginning and ending as close to the extreme edges as practicable. The centerline for each of the strips of retroreflective sheeting (or each reflex reflector) must be between 375 mm (15 inches) and 1,525 mm (60 inches) above the road surface when measured with the trailer empty or unladen, or as close as practicable to this area.

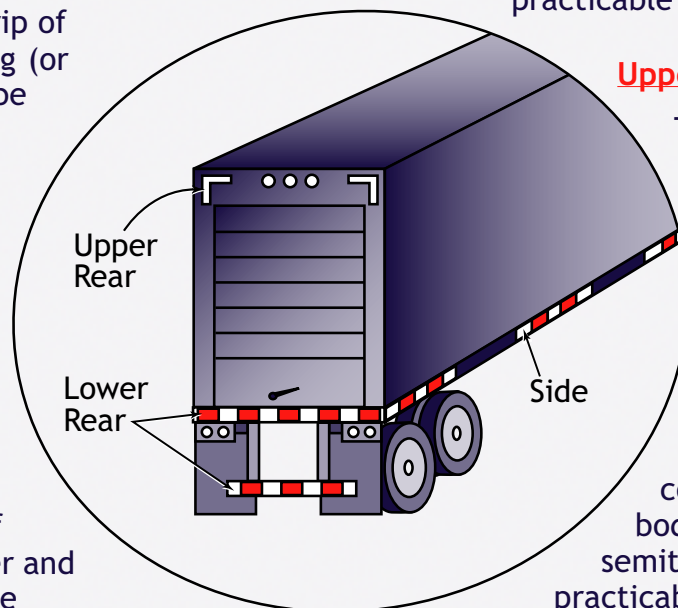

Upper rear area of the trailer

Two pairs of white strips of retroreflective sheeting (or reflex reflectors), each pair consisting of strips 300 mm (12 inches) long, must be positioned horizontally and vertically on the right and left upper corners of the rear of the body of each trailer and semitrailer, as close as practicable to the top of the trailer and as far apart as practicable. If the perimeter of the body, as viewed from the rear, is not square or rectangular, the conspicuity treatments may be applied along the perimeter, as close as practicable to the uppermost and outermost areas of the rear of the body on the left and right sides.

Requirements for Trailers Manufactured Before December 1, 1993 (49 CFR 393.13)

On March 31, 1999, the Federal Motor Carrier Safety Regulations (FMCSRs) were amended to require that motor carriers engaged in interstate commerce install retroreflective tape or reflex reflectors on the sides and rear of semitrailers and trailers that were manufactured *prior* to December 1, 1993, have an overall width of 2,032 mm (80 inches) or more, and a gross vehicle weight rating (GVWR) of 4,536 kg (10,001 pounds) or more. As a result of that final rule, motor carriers must install retroreflective tape or reflex reflectors on their older trailers by June 1, 2001. The

FMCSA is allowing motor carriers a certain amount of flexibility in terms of the colors or color combinations until June 1, 2009, but requires that all older trailers be equipped with conspicuity treatments identical to those mandated for new trailers by 2009. The retrofitting requirements may be found at 49 CFR 393.13.

In the simplest terms, the locations at which the conspicuity materials must be placed on the older trailers is the same as the trailers manufactured on or after December 1, 1993. The only differences are that: flexibility is allowed in terms of the color, there is no requirement for certification marking on the conspicuity material, and there is no requirement for conspicuity materials on the rear impact guard.

Special Note on the Use of Conspicuity Treatments In Lieu of Reflex Reflectors on Trailers

Trailers which are equipped with conspicuity material which meets the requirements of FMVSS No. 108 are not required to be equipped with the reflex reflectors listed in the regulations if –

- (i) The conspicuity material is placed at the locations where reflex reflectors are required; and
- (ii) The conspicuity material when installed on the motor vehicle meets the geometric visibility requirements for the reflex reflectors.

Requirements for Truck Tractors Manufactured After July 1, 1997 (§ 393.11)

On August 8, 1996, the NHTSA published a final rule requiring that truck tractors manufactured on or after July 1, 1997, be equipped with red-and-white retroreflective material similar to that required on the rear of the trailers they tow to increase nighttime conspicuity. Manufacturers may choose either retroreflective sheeting or reflex reflectors. In the case of truck tractors delivered with a temporary mudflap arrangement rather than permanent equipment, the requirement for retroreflective material near the top of the

mudflap may be satisfied with material carried by the temporary mudflap brackets that are transferable to the permanent mudflap system. Retroreflective material is also required near the top of the cab in a pattern similar to that used on trailers.

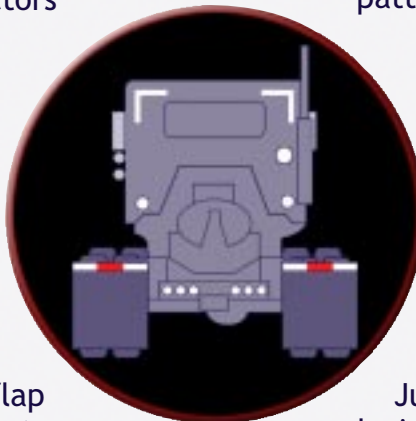

Currently, § 393.11 requires that all lamps and reflective devices on motor vehicles placed in operation after March 7, 1989, meet the requirements of FMVSS No. 108 in effect on the date of manufacture. Therefore, truck tractors manufactured on or after July 1, 1997, must have reflective devices of the type and in the locations specified by FMVSS No. 108, including the conspicuity treatments.

Reprint of Retrofitting Requirements and Examples of Conspicuity Treatments

§ 393.13 Retroreflective Sheeting and Reflex Reflectors Requirements for Semitrailers and Trailers Manufactured Before December 1, 1993.

(a) Applicability

All trailers and semitrailers manufactured prior to December 1, 1993, which have an overall width of 2,032 mm (80 inches) or more and a gross vehicle weight rating of 4,536 kg (10,001 pounds) or more, except trailers that are manufactured exclusively for use as offices or dwellings, pole trailers (as defined in § 390.5), and trailers transported in a driveaway-towaway operation, must be equipped with retroreflective sheeting or an array of reflex reflectors that meet the requirements of this section. Motor carriers have until June 1, 2001 to comply with the requirements of this section.

(b) Retroreflective sheeting and reflex reflectors

Motor carriers are encouraged to retrofit their trailers with a conspicuity system that meets all of the requirements applicable to trailers manufactured on or after December 1, 1993, including the use of retroreflective sheeting or reflex reflectors in a red and white pattern (see Federal Motor Vehicle Safety Standard No. 108 (49 CFR 571.108), S5.7, Conspicuity systems). Motor carriers which do not retrofit their trailers to meet the requirements of FMVSS No. 108, for example by using an alternative color pattern, must comply with the remainder of this paragraph and with paragraph (c) or (d) of this section. Retroreflective sheeting or reflex reflectors in colors or color combinations other than red and white may be used on the sides or lower rear area of the semitrailer or trailer until June 1, 2009. The alternate color or color combination must be uniform along the sides and lower rear area of the trailer. The retroreflective sheeting or reflex reflectors on the upper rear area of the trailer must be white and conform to the requirements of FMVSS No. 108 (S5.7). Red retroreflective sheeting or reflex reflectors shall not be used along the sides of the trailer

unless it is used as part of a red and white pattern. Retroreflective sheeting shall have a width of at least 50 mm (2 inches).

(c) Locations for retroreflective sheeting

(1) Sides

Retroreflective sheeting shall be applied to each side of the trailer or semitrailer. Each strip of retroreflective sheeting shall be positioned as horizontally as practicable, beginning and ending as close to the front and rear as practicable. The strip need not be continuous but the sum of the length of all of the segments shall be at least half of the length of the trailer and the spaces between the segments of the strip shall be distributed as evenly as practicable. The centerline for each strip of retroreflective sheeting shall be between 375 mm (15 inches) and 1,525 mm (60 inches) above the road surface when measured with the trailer empty or unladen, or as close as practicable to this area. If necessary to clear rivet heads or other similar obstructions, 50 mm (2 inches) wide retroreflective sheeting may be separated into two 25 mm (1 inch) wide strips of the same length and color, separated by a space of not more than 25 mm (1 inch).

(2) Lower rear area

The rear of each trailer and semitrailer must be equipped with retroreflective sheeting. Each strip of retroreflective sheeting shall be positioned as horizontally as practicable, extending across the full width of the trailer, beginning and ending as close to the extreme edges as practicable. The centerline for each of the strips of retroreflective sheeting shall be between 375 mm (15 inches) and 1,525 mm (60 inches) above the road surface when measured with the trailer empty or unladen, or as close as practicable to this area.

(3) Upper rear area

Two pairs of white strips of retroreflective sheeting, each pair consisting of strips 300 mm (12 inches) long, must be positioned horizontally and vertically on the right and left upper corners of the rear of the body of each trailer and semitrailer, as close as practicable to

the top of the trailer and as far apart as practicable. If the perimeter of the body, as viewed from the rear, is not square or rectangular, the strips may be applied along the perimeter, as close as practicable to the uppermost and outermost areas of the rear of the body on the left and right sides.

(d) Locations for reflex reflectors

(1) Sides

Reflex reflectors shall be applied to each side of the trailer or semitrailer. Each array of reflex reflectors shall be positioned as horizontally as practicable, beginning and ending as close to the front and rear as practicable. The array need not be continuous but the sum of the length of all of the array segments shall be at least half of the length of the trailer and the spaces between the segments of the strip shall be distributed as evenly as practicable. The centerline for each array of reflex reflectors shall be between 375 mm (15 inches) and 1,525 mm (60 inches) above the road surface when measured with the trailer empty or unladen, or as close as practicable to this area. The center of each reflector shall not be more than 100 mm (4 inches) from the center of each adjacent reflector in the segment of the array. If reflex reflectors are arranged in an alternating color pattern, the length of reflectors of the first color shall be as close as practicable to the length of the reflectors of the second color.

(2) Lower rear area

The rear of each trailer and semitrailer must be equipped with reflex reflectors. Each array of reflex reflectors shall be positioned as horizontally as practicable, extending across the full width of the trailer, beginning and ending as close to the extreme edges as practicable. The centerline for each array of reflex reflectors shall be between 375 mm (15 inches) and 1,525 mm (60 inches) above the road surface when measured with the trailer empty or unladen, or as close as practicable to this area. The center of each reflector shall not be more than 100 mm (4 inches) from the center of each adjacent reflector in the segment of the array.

(3) Upper rear area

Two pairs of white reflex reflector arrays, each pair at least 300 mm (12 inches) long, must be positioned horizontally and vertically on the right and left upper corners of the rear of the body of each trailer and semitrailer, as close as practicable to the top of the trailer and as far apart as practicable. If the perimeter of the body, as viewed from the rear, is not square or rectangular, the arrays may be applied along the perimeter, as close as practicable to the uppermost and outermost areas of the rear of the body on the left and right sides. The center of each reflector shall not be more than 100 mm (4 inches) from the center of each adjacent reflector in the segment of the array.

Examples of Conspicuity Treatment

Trailers –

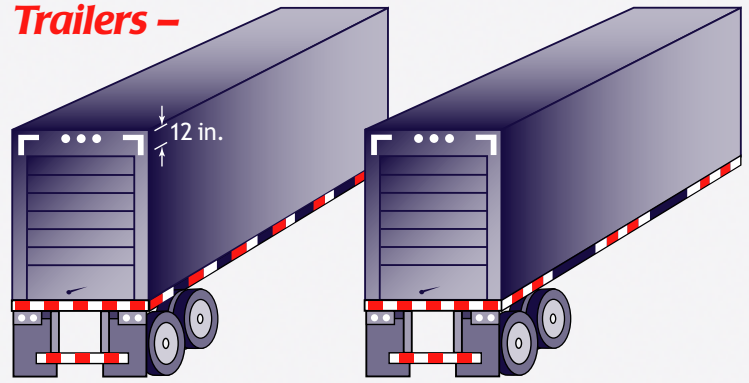

Flatbeds –

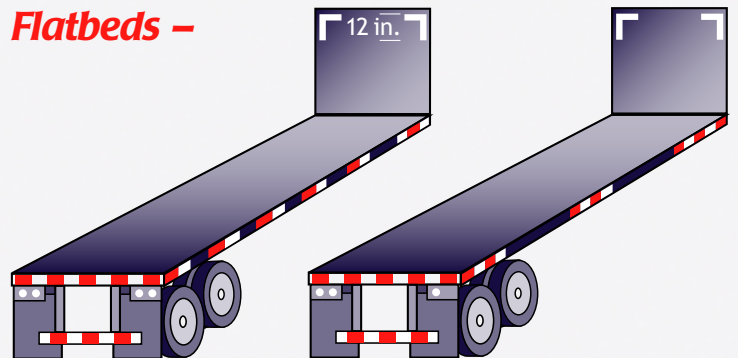

Tankers –

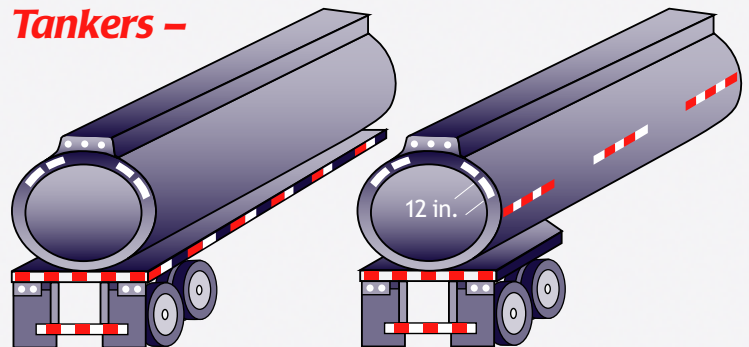

Tractors –

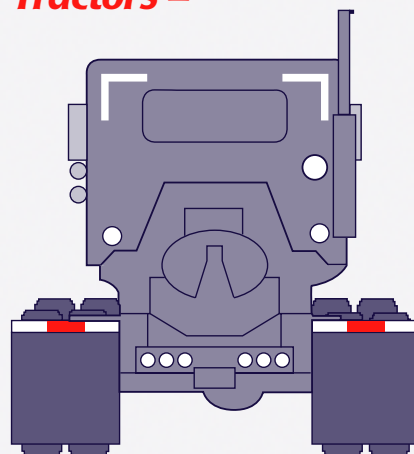

Illustrations courtesy of
3M Commercial Graphics Division.

